



40 Huntingwood Drive Huntingwood NSW 2148

Phone: (02) 8825 1999 Website: www.aeroflowperformance.com

AEROFLOW PERFORMANCE

UNIVERSAL 21 CIRCUIT WIRING HARNESS

WARNING!

THIS PRODUCT REQUIRES DETAILED KNOWLEDGE OF AUTOMOTIVE SYSTEMS. WE RECOMMEND THAT THIS INSTALLATION BE CARRIED OUT BY A QUALIFIED AUTOMOTIVE ELECTRICIAN.

INTRODUCTION

Congratulations on your purchase of Aeroflow Performance universal 21 circuit wiring harness. Aeroflow Performance products cannot and will not be responsible for any damage, or other conditions resulting from misapplication of the parts described herein. However, it is our intention to provide the best possible products for our customer, products that perform properly and satisfy your expectations. Should you have any questions? Please call technical support at +61 2 8825 1900 and have the product part number on hand when calling.

The Aeroflow Performance universal 21 circuit wiring harness is designed for use in most cars or trucks that have the engine mounted in the front of the vehicle and can mount the fuse block under the dash. Since this harness can be installed in many different types of vehicles, the installation may require some modifications to suit the options and features of your vehicle. When using aftermarket accessories and equipment, use the wiring diagrams provided with those products (instead of this manual). The wiring included in this wiring harness is coloured and labelled for easy identification of each wire.

Please read completely through these instructions before starting this installation. Before attempting installation please note the following:

- Disconnect both battery cables before starting this installation.
- Install main ground cables that go between the chassis and engine and between the engine and body. Ground all accessories. Ground wires are not included with this kit.
- All Ground connections must be made free of dirt, rust, or paint (metal to metal connection)
- Route wiring away from sharp edges, heat, and any moving parts like fan belts, steering gear, driveshaft's, bonnet hinges/latches and the exhaust system.
- Use a grommet whenever wiring is passed through a sheet metal or fiberglass panel to prevent wiring rubbing though and causing a short.
- Fasten the wiring down with p-clamps and/or cable ties.
- We recommend to upgrade the starter and alternator wiring if using high output components.

Prepare the Wiring Harness

Spread out the harness on a large work area to help with the organization of so many wires. Start with the fuse block and organize the wires that are attached to it into the 4 sections Review the wiring worksheet and wiring diagram to assist with this process. Use cable ties to organize the wiring into these 4 groups. Ensure to write down on a work sheet where each wire will be going to and which wires are to be removed.

Mounting the Fuse Box

The fuse block should be mounted under the dash on the driver's side of the vehicle. The fuse block must be securely mounted on a flat surface. The fuse block must be mounted away from any moving components (i.e. pedals & steering shaft). Find a suitable location that is accessible for inspection and replacement of fuses. Mount the fuse block using bolts or screws using both holes at the outer edge of the feet on the fuse block.

Note where the wires exit the fuse block and find a suitable location where these wires can go through the firewall and into the engine compartment. Find a location where the wiring won't interfere with other components and will be away from heat or moving components that may damage the wire.

Routing and Attaching Wires

This wiring kit is broken down into 4 simple sections once the cable tie has been removed (note do not remove the one closest to the fuse panel just yet). The four sections are:

Section 1 – Rear Section of Vehicle

White Wire (labelled- 43 Dome Light) (16awg) wire to interior dome light in centre of roof

Yellow Wire (labelled- 41 Fuel Pump) (16awg) wire to ignition power wire for fuel pump

Pink Wire (labelled 40 Fuel Gauge) (16awg) wire to fuel sender signal in fuel tank

Yellow Wire (labelled - 20 Left Rear Turn) (16awg) wire to the left rear directional light. This should be connected to the high side of a dual filament bulb.

Green Wire (labelled - 21 Right Rear Turn) (16awg) wire to the right rear directional light. This should be connected to the high side of a dual filament bulb.

Orange Wire (labelled – 19 Third Brake) (16awg) wire the third brake light positive side. If you are not using a third brake light this wire can be either taped into the harness or removed.

Brown Wire (labelled – 35 Left Tail Park) (16awg) wire to the rear taillight of the vehicle, it will need to be spliced to run to both lights. This wire should be connected to the low side of a dual filament bulb.

Dark Green (labelled – 38 Left Backup) (16awg) wire to the rear reverse lights of the vehicle, it may need to be spliced if you have two reverse lights.

Light Green (labelled – 42 Trunk Light) (16awg) wire to interior boot light.

Section 2 – Charge System / Front End Lights

White Wire (labelled- 44 Alt Exciter) (14awg) wire to alternator exciter wire on alternator wiring plug terminal. If using a late model GM alternator a pre wired black plug is included in the small parts bag for added convenience. Just plug into alternator and run the eyelet terminal to the alternator stud or battery terminal of alternator.

Red Wire (labelled – 58 Alt Power) (12awg) wire to battery terminal or stud on the alternator. If using a alternator that is rated for more than 80amps it is important to run a alternator bypass wire that is provided in the small parts bag (long black 16awg wire with eyelet). This will be required to wire from the same above stud on the alternator to the stud on the starter motor solenoid.

Large Red Wire (labelled – 52 Solenoid Power) (10awg) wire to starter relay or starter solenoid via fuse or fusible link. **NOTE** : Failure to install fusible link voids any and all warranty on this wiring harness.

Purple Wire (labelled – 32 Ign Switch Start) (12awg) wire to starter solenoid to the neutral safety switch to the S terminal on a GM starter solenoid. Run the purple neutral safety switch wire from the solenoid terminal on the ignition switch to the neutral safety switch. If you are not running a neutral safety switch this wire can be extended and run straight to the S terminal on your starter. A extra piece of both purple wire is included in the small parts bag to help extend the wires for the neutral safety switch.

Dark Green (labelled – 28 Left High Beam) (16awg) wire to black three pin headlight plug supplied with this kit along with the headlight ground wires to the connectors as per this diagram :

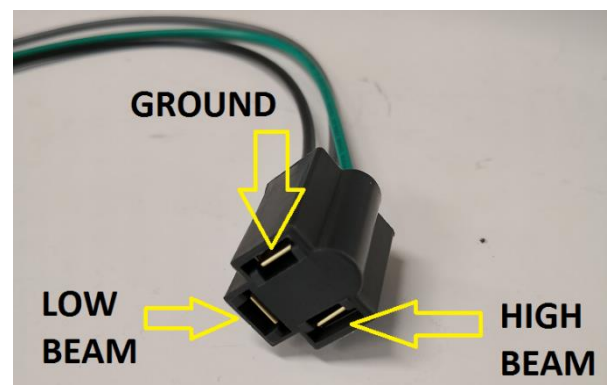

Light Pink (labelled – 24 Left Low Beam) (16awg) wire to black three pin headlight plug supplied with this kit along with the headlight ground wires to the connectors as per above diagram

Dark Blue (labelled – 17 Right Front Signal) (16awg) wire to the right front directional lamp. This would be connected to the high side if you're using a dual filament bulb for park/turn

Light Blue (labelled – 15 Left Front Signal) (16awg) wire to the left front directional lamp. This would be connected to the high side if you're using a dual filament bulb for park/turn

Brown (labelled – 48 Left Front Park) (16awg) wire to left front park light. If you are using a dual filament bulb it should be connected to the low filament.

Brown (labelled – 49 Right Front Park) (16awg) wire to right front park light. If you are using a dual filament bulb it should be connected to the low filament.

Purple Wire (labelled – 51 Power Antenna) (16awg) wire to antenna for radio that requires power to extend.

Black Wire (labelled - 46 AC Compressor) (16awg) wire to a heater/ac control unit or compressor. Follow instructions provided by manufacture of a/c compressor for proper connection.

Light Blue (labelled – 56 Oil Sending) (16awg) wire to the oil pressure sender on engine

Grey Wire (labelled – 47 Fan Fan) (16awg) wire to a fan relay (sold separately AF49-1006 or AF49-1048) . Wire to terminal 87 of the relay. DO NOT use as direct power for the fan. Run power direct from battery with in-line fuse based on fan specs.

Purple Wire (labelled – 45 Tachometer) (16awg) wire to the tach terminal on a GM HEI distributor or the negative side of the coil or to a tach connector on a aftermarket ignition module.

Green Wire (labelled – 55 Horn) (16 awg) wire to the positive connection on your horn.

Pink Wire (labelled – 55 Coil Pos) (16awg) wire to the positive connection on your coil.

Red Wire (labelled – 50 Choke Power) (16awg) wire to electric choke if not required tuck back into loom

Green Wire (labelled – 72 Temp Sender) (16awg) wire to water/coolant temperature sender on engine.

Section 3 - Ignition Switches

Turn Signal Switch Connectors

This kit was designed to function with a factory GM style switch and column plug. There are two types provided with this kit that can be used depending on your application. The first plug is the 3-7/8" in length plug found on GM columns from 1969-1974, also on a variety of aftermarket steering columns. If you are using a later 1975 and on the plug is a 4-1/4" in length and has a flap to lock down each terminal. Photo Shown below for difference.

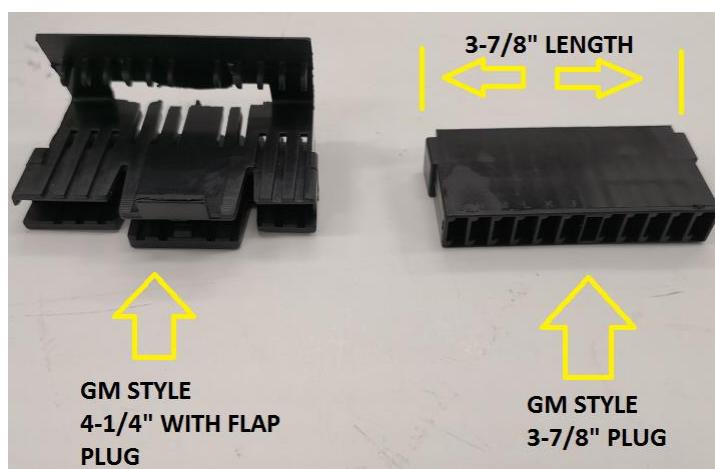

Each Connector is individual marked with letters to correspond with the below table for what wire should be inserted into plug.

WIRE COLOUR (LOOM)	WIRE DESCRIPTION (LOOM)	WIRE NUMBER (LOOM)	LETTER CODE ON PLUG	GM OEM PLUG WIRE COLOUR
Purple	Turn Flasher	25	L	Purple
Orange	Third Brake	19	P	White
White	Brake Switch	18	P	White
Dark Blue	Right Signal	17	J	Blue
Dark Blue	Front Right Signal	16	J	Blue
Light Blue	Light Front Signal	15	H	Light Blue
Dark Blue	Left Signal	14	H	Light Blue
Light Green	Right Rear Turn	21	N	Green
Yellow	Left Rear Turn	20	M	Yellow
Dark Green	Horn Switch	26	G	Black
Brown	Hazard	27	K	Brown

Dimmer Switch (Black 3 Pin Plug)

Light Pink Wire (labelled – 24 Left Low Beam) (16awg) connect to dimmer switch shown in diagram below

Dark Green Wires (labelled – 28 / 73 High Beam) (16awg) connect to dimmer switch shown in diagram below

Light Blue Wire (labelled – 22 Dimmer Power) (14awg) connect to dimmer switch shown in diagram below

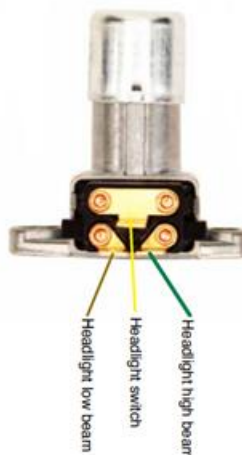
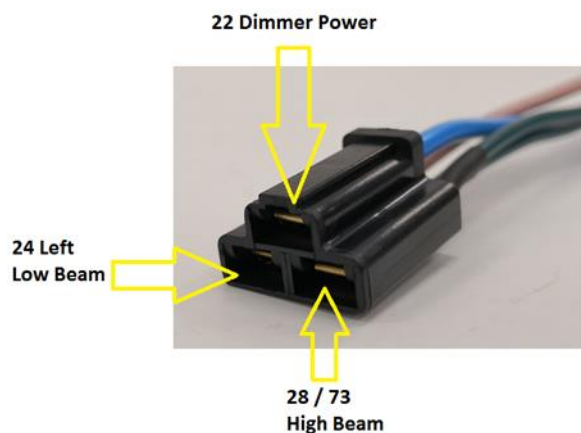

Dimmer Switch (GM Style)

The Left Bottom Wire (Headlight Low Beam) will run to your headlight low beam control circuit via the black plug shown below (24 Left Low Beam Light Pink wire)

The Bottom Right Wire (Headlight High Beam) will run to your headlight high beam control circuit via the black plug shown below (28 / 73 High Beam Dark Green Wires)

The Top Wire (Headlight Switch) will run to your Headlight switch via the black plug shown below (22 Dimmer Power Light Blue Wire)

Connection Kits

Use the supplied harness plugs and the appropriate wiring diagram for your switch to determine which wires will go where. GM used multiple style switches with different wiring pin outs; please verify which style you need. Our cavity diagram is a generic one that is common for most GM vehicles. Once the wires are installed in their appropriate cavity, the white plug will be plugged into the switch first using the black connector to secure it in place. Even if there are no wires in the black pigtail plug in the connector to retain the white one.

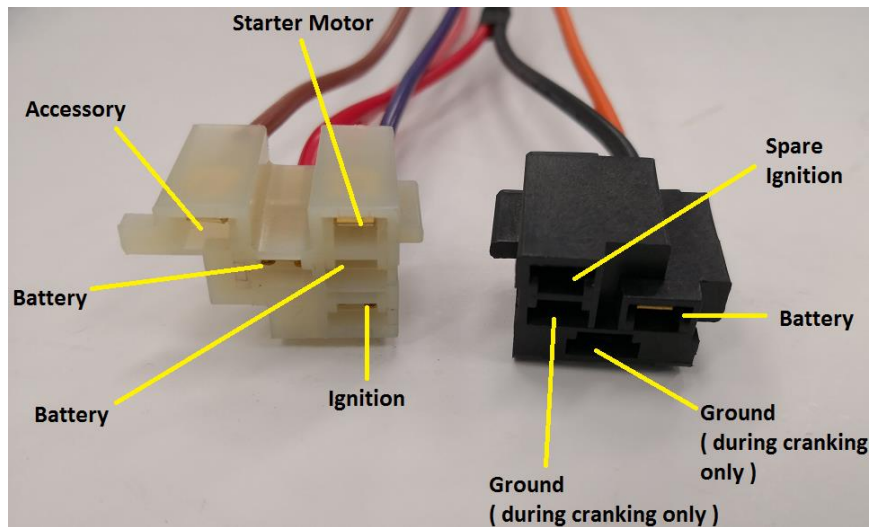

Wire Colour	Wire Description	Wire Number
Orange	Ignition Switch ACC	31
Red	Ign Switch Power	33
Pink	Ign Switch Coil	30
Purple	Ign Switch Start	32

Section 4 – Dash Section

Loom one

Light Blue Wire (labelled – 22 Dimmer Power) (14awg) wire to headlight switch dimmer connection (see diagram at the end of this section).

Dark Blue Wire (labelled – 16 Right Signal Ind) (16awg) wire to instrument cluster in dash to right hand turn signal indicator light (see diagram at the end of this section).

Dark Blue Wire (labelled – 14 Left Signal Ind) (16awg) wire to instrument cluster in dash to left hand turn signal indicator light (see diagram at the end of this section).

Dark Green Wire (labelled – 73 High Beam idn) (16awg) wire to instrument cluster in dash to high beam indicator light (see diagram at the end of this section).

White Wire (labelled – 18 Brake Switch) (16awg) wire to the output side of the brake light switch

Pink Wire (labelled – 40 Fuel Gauge) (16awg) wire to instrument cluster in dash to the fuel level gauge (see diagram at the end of this section).

Dark Green Wire (labelled – 38 Left Backup) (16awg) wire to reverse switch on steering column or extend wires if located in a different location such as gearbox.

Brown Wire (labelled – 35 Left Tail Park) (14awg) wire to headlight switch to rear tail lamp connector pin (see diagram at the end of this section).

Loom Two

Light Blue Wire (labelled – 56 Oil Sending) (16awg) wire to instrument cluster in dash to the oil pressure gauge (see diagram at the end of this section).

Light Green Wire (labelled – 72 Temp Sender) (16awg) wire to instrument cluster in dash to the water temperature gauge (see diagram at the end of this section).

Purple Wire (labelled – 45 Tachometer) (16awg) wire to instrument cluster in dash to the tachometer/RPM gauge (see diagram at the end of this section).

Brown Wire (labelled – 49 Left Front Park) (16awg) wire to headlight switch to front parking lamp connector pin. Two options are available one will operate the front park lights full time the other option will turn the parking lights off once the headlights are switched on (see diagram at the end of this section).

Purple Wire (labelled – 51 Power Antenna) (16awg) wire to radio in vehicle (if no power antenna in vehicle disregard wire)

Black Wire (labelled – 46 AC Compressor) (16awg) wire to a heater/ac control unit inside the vehicle cabin. Follow instructions provided by manufacture for proper connection.

Grey Wire (labelled – 47 Fan Fan) (16awg) wire to a fan relay (sold separately AF49-1006 or AF49-1048) . Wire to terminal 86 of the relay. DO NOT use as direct power for the fan. Run power direct from battery with in-line fuse based on fan specs.

Loom Three

Red Wire (labelled – 09 Gauge Power) (16awg) wire to instrument cluster in dash to the 12 volt ignition connector (see diagram at the end of this section).

Light Pink Wire (labelled – CTG Lighter) (16awg) wire to cigarette lighter in vehicle cabin if not required disregard wire.

Pink Wire (labelled – 02 Cruise Power) (16awg) wire to directly to the cruise control module. If you do not have cruise control, it can be used to power an accessory requiring a switched 12v power source.

Blue Wire (labelled – 07 Wiper Power) (16awg) wire to either the wiper switch or wiper motor terminal which ever requires the 12 volt ignition power depending on which set-up is being used

Red Wire (labelled – 05 Radio IGN) (16awg) wire to the radio unit in cabin to the ignition power wire on the radio (if aftermarket please follow manufacturer instructions).

Red Wire (labelled – 06 Radio Constant Power) (16awg) wire to the radio unit in cabin to the 12 volt battery constant power wire on the radio (if aftermarket please follow manufacturer instructions).

Orange Wire (labelled – 11 Brake Switch Power) (16awg) wire to the input side of the brake light switch

Black Wire (labelled – 03 AC/Heat Power) (16awg) wire to a heater/ac control unit power wire inside the vehicle cabin. Follow instructions provided by manufacture for proper connection.

Grey Wire (labelled – 10 Fan Power) (16awg) wire to ignition power to a fan relay (sold separately AF49-1006 or AF49-1048) . Wire to terminal 30 of the relay. DO NOT use as direct power for the fan. Run power direct from battery with in-line fuse based on fan specs.

Dark Green (labelled – 13 Backup Power) (16awg) wire to reverse switch to the power side to provide ignition power for switch. If you do not have back up lights, it can be used to power an accessory requiring a switched 12v power source.

Large Red Wire (labelled – 01 Head Light Power) (12awg) wire to headlight switch to battery feed connector terminal

Yellow Wire (labelled – 04 Window Power) (14awg) wire to window switch ignition power terminal

Large Yellow Wire (labelled – 12 Door Lock Power) (12awg) wire to door lock control module for a constant 12 volt battery source.

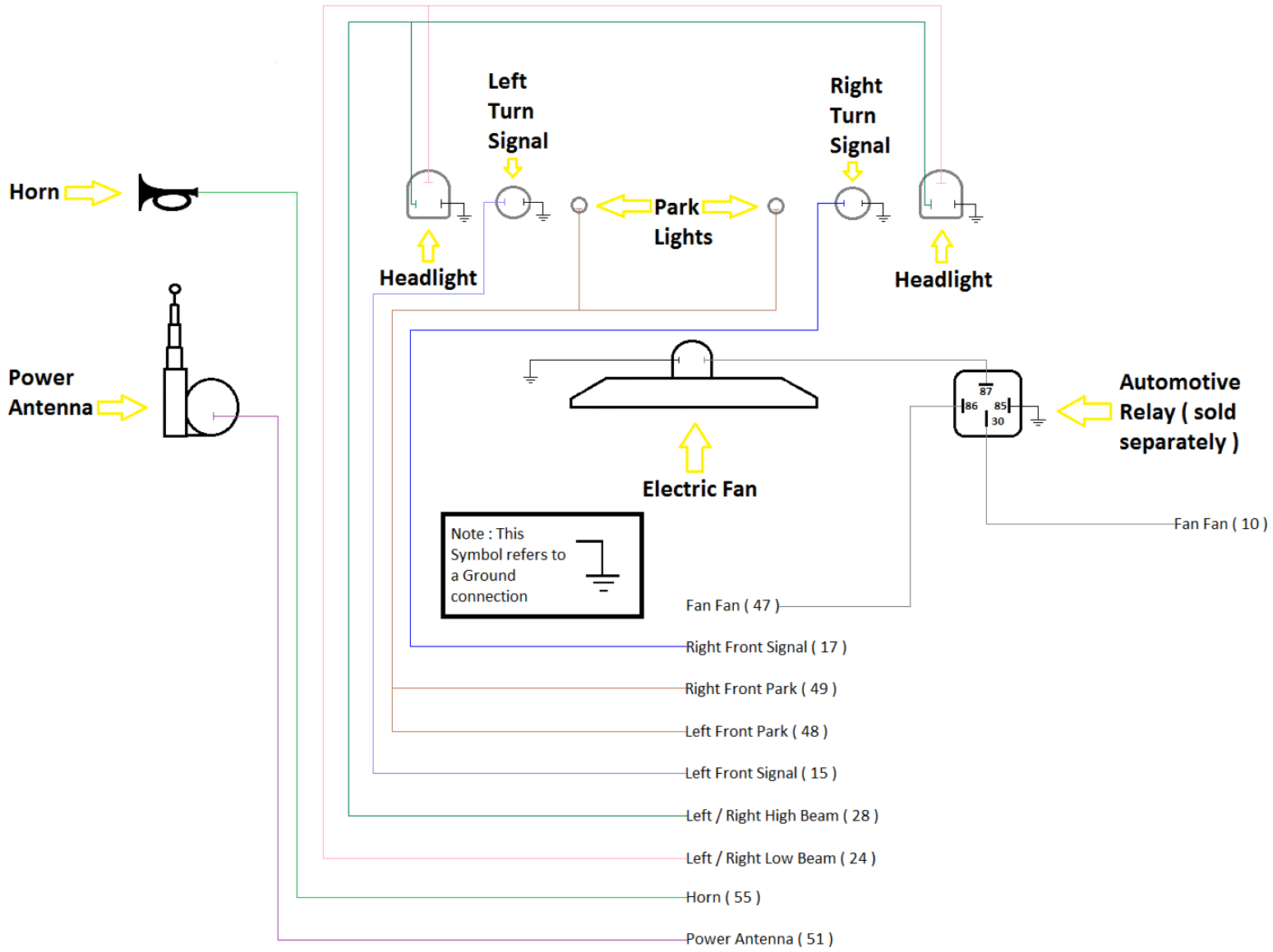

For more information or technical enquires

Contact: Aeroflow Performance on

Phone: (02) 8825 1979 Website: www.aeroflowperformance.com

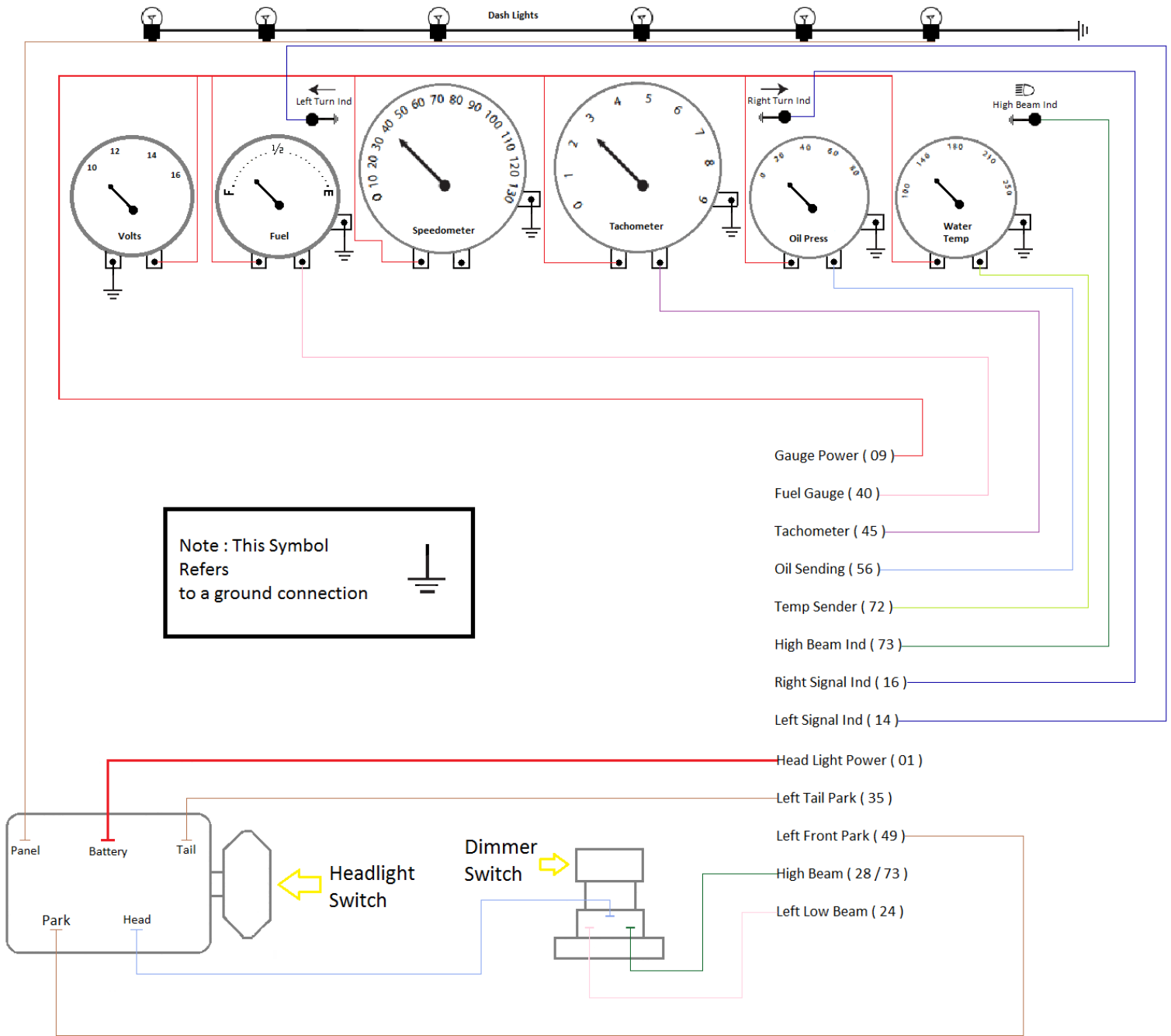

For more information or technical enquires

Contact: Aeroflow Performance on

Phone: (02) 8825 1979 Website: www.aeroflowperformance.com

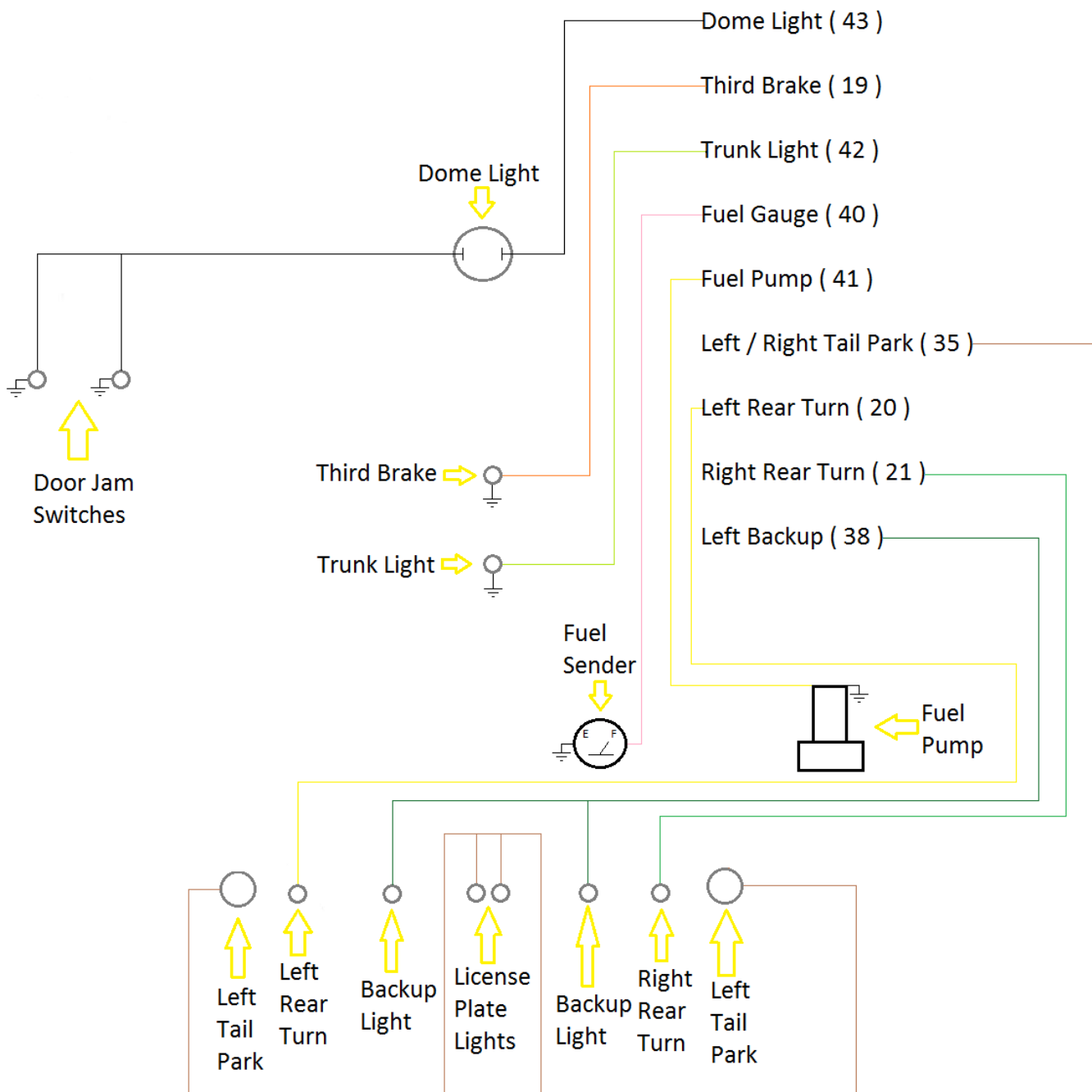

For more information or technical enquires

Contact: Aeroflow Performance on

Phone: (02) 8825 1979 Website: www.aeroflowperformance.com

WORKSHEET