



40 Huntingwood Drive Huntingwood NSW 2148

Phone: (02) 8825 1999 Website: www.aeroflowperformance.com

INSTALLATION MANUAL

AEROFLOW PERFORMANCE

STARTER MOTOR

WARNING!

BEFORE PROCEEDING WITH INSTALLATION PLEASE READ INSTRUCTIONS CAREFULLY. THIS PRODUCT REQUIRES DETAILED KNOWLEDGE OF AUTOMOTIVE SYSTEMS. WE RECOMMEND THAT THIS INSTALLATION BE CARRIED OUT BY A QUALIFIED AUTOMOTIVE TECHNICIAN.

These instructions must be read and fully understood before beginning the installation. Failure to follow these instructions may result in poor performance, vehicle damage, personal injury or death. If these instructions are not fully understood, installation should not be attempted.

INTRODUCTION

Congratulations on your purchase of the Aeroflow Performance starter motor. Aeroflow Performance products cannot and will not be responsible for any damage, or other conditions resulting from misapplication of the parts described herein. However, it is our intention to provide the best possible products for our customer, products that perform properly and satisfy your expectations. Should you have any questions? Please call technical support at +61 2 8825 1900 and have the product part number on hand when calling.

Aeroflow XPRO Nippon Denso style high torque starter motors will be sure to get your engine cranking. The unique aluminium housing is designed to withstand high heat, eliminating hot start problems and the black powder coated body allows for extra protection against corrosion. The adjustable multi-angle mounting block allows different mounting positions to clear multiple header, oil pan configurations and suspension parts. These Aeroflow XPRO starters are sealed units with rubber O-rings and have easily replaceable plungers and contacts, making them a completely serviceable item. The 2kw / 2.7hp starter is recommended for 400cu + engines and up to 15:1 compression ratio and utilizes a 2.86:1 gear reduction.

It is important for long starter life that the ring gear be round and true. Check the ring gear in at least six places verifying that the clearance for the starter is the same in all locations. If not remove the ring gear and make sure the mounting surface of the crankshaft is clean and free of paint build up or rust. Reinstall the ring gear and properly torque the mounting bolts. If this does not correct the problem, replace the ring gear.

The switch used for a battery disconnect is very important. All the starter current will go across this switch during cranking which, depending on the starter, can be as high as 700A. After the engine is running, all the current from the alternator will be running across this switch. Therefore, make sure that the switch that is being used can handle these amounts of current. Switches are rated in intermittent amps and continuous amps. The intermittent rating should match or exceed the amount the starter will pull, and the continuous rating should match or exceed the amount the alternator can produce. Using a switch that is too small will result in voltage loss and possible switch failure.

Heat is the enemy of any electrical device. Therefore, heat shields between the headers and starter are recommended to prolong the life of the starter. Starter motor heat aluminised starter heat shield are available separately (AF91-6010).

For more information or technical enquires

Contact: Aeroflow Performance on

Phone: (02) 8825 1979 Website: www.aeroflowperformance.com

INSTALLATION INSTRUCTIONS

Proper installation of this starter motor is the responsibility of the installer. Improper modification or installation will void your warranty and may result in vehicle damage or personal injury.

Caution: Starter replacement often requires working under a vehicle handling heavy components. Always be sure to use proper safety precautions and safety jack stands on a level surface to support the vehicle. Failure to follow these precautions could result in serious personal injury!

Both Positive & Negative battery cables must be disconnected at battery prior to installation.

Below is a basic guideline and each specific application may vary.

This Starter motor is intended for use on Holden / GM LS1 to LS7 V8 engines with 168 tooth flywheels.

If you are replacing an existing starter which has failed, pay careful attention to the mode of failure, and look for any mechanical/ electrical problems somewhere else in your application which could be corrected to avoid the problem happening again. While removing your old starter, pay attention for fasteners which may have been damaged or loose. Also look for any cracks, metal transfer, or abnormal ring gear wear which may suggest other problems. Special care to remedy problems at this point can avoid repeat failures.

1. Disconnect the ground cable from the battery.
2. Disconnect all wire connections from the starter motor and label wires for future replacement.
3. Remove all bolts holding in the starter motor. Ensuring not to discard these as they may still be required.
4. Make sure the starter mounting flange on the engine block is clean and smooth, free of any rust, dirt or paint.
5. Install the starter with the supplied hardware. It is recommended to leave the shims out until the pinion gear to ring gear teeth mesh is checked. Torque the starter mounting bolts to the engine manufacturer's specifications.
6. Check that the position of the solenoid is away from direct heat sources and other components. If there are clearance problems, the starter housing can be rotated to move the location of the solenoid. This is done by removing the three bolts on the mounting block and repositioning the starter motor.
7. With the starter installed, check the clearance between the ring gear and the edge of the pinion gear. This is vital to starter operation and starter/ ring gear life. There should be at least 1/16". It is recommended to check this clearance in at least three places around the flex plate. Please follow the step below to shim the starter which should be carried out every time.

GM Starters Shimming Installation Instructions

WARNING!

Before installation you MUST Understand The Need For Proper starter pinion to flywheel clearance!

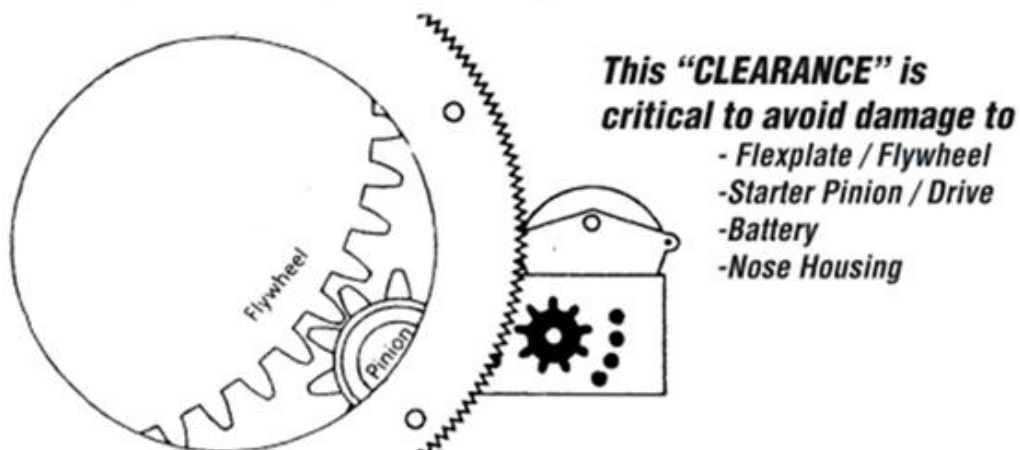

This is not needed for FORD and CHRYSLER as they have a fixed starter pinion to Flexplate / Drive plate clearance.

GM / HOLDEN HAVE AN ADJUSTABLE CLEARANCE

WHY? ***Mounting pad tolerances and hole locations vary from block to block. This moves the starter pinion gear to flexplate / flywheel mesh by varying distances.***

REMEMBER:

Mounting pad tolerances and hole locations + nose housing tolerances = THE NEED TO CHECK FOR PROPER CLEARANCE AND SHIM AS REQUIRED!

Important: Most causes of premature starter failure of GM Pad-Mounted starters are the result of improper shimming, regardless of whether the old starter had shims or not. **You must inspect the clearance** of this new starter as it may or may not require shimming.

Step 1

Remove the inspection cover and **EXAMINE THE ENTIRE FLEXPLATE / FLYWHEEL** for visual problems
Worn, chipped or broken teeth.
Bent flexplate / flywheel.
Incorrectly cut teeth.

Step 2

Insert a screwdriver behind the starter pinion / drive of starter motor mount / drive end plate. Move the starter pinion / drive out toward flexplate / flywheel so that starter pinion and ring gear teeth mesh. (see figure 1).

Step 3

Centre a pinion tooth and check clearance. (Looking for .030"-.060")(see figure 2). A convenient plug gauge is a common paperclip, which is typically .035". **IMPORTANT!** Check at least 3 locations 120 Degree apart for proper clearance. Shim as **REQUIRED** at **MINIMUM** clearance location.

Step 4

PROPER SHIMMING,

TO INCREASE CLEARANCE (SEE FIGURE A)

Use entire shim across both holes (see figure 3). .015" shim increases clearance approx. .0075" moving the starter down and out, away from the flexplate / flywheel.

TO DECREASE CLEARANCE (SEE FIGURE B)

Use 1/2" shim only on the outer mounting bolt hole (see figure 4). This moves the starter up and inwards to the flexplate / flywheel. .015" shim decreases clearance approx. .010"

THE STARTER PINION GEAR / DRIVE TELLS THE STORY:



Incorrect
Wear Pattern
Not Enough Clearance
(Shims Needed)



Correct
Wear Pattern



Incorrect
Wear Pattern
Too Much Clearance
(Use Less Shims)

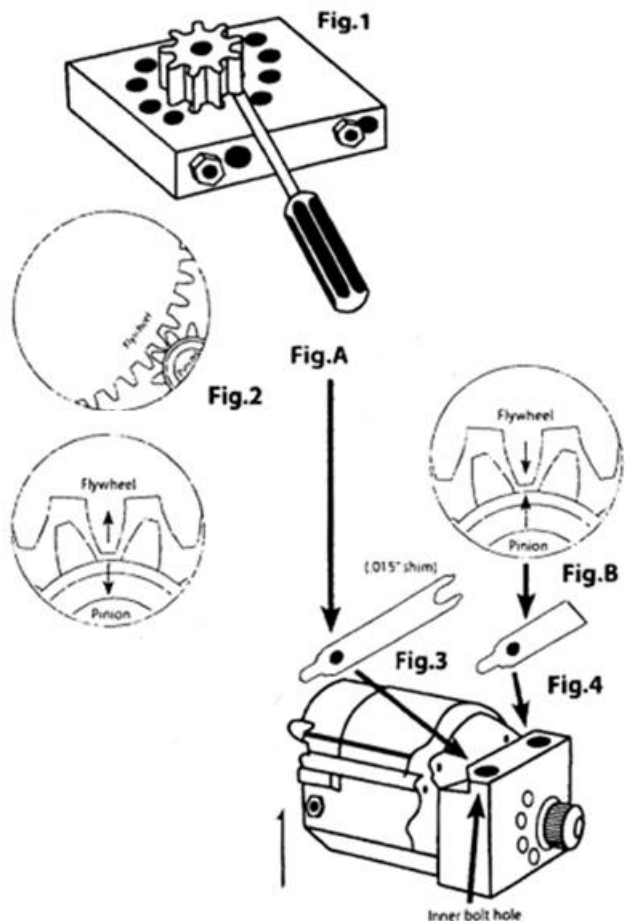

NOTE: Check the starter end plate is correctly mounted and fasteners are tight to avoid any pinion gear / drive mesh problems.

8. The main battery cable for the starter power needs to be attached to the largest solenoid terminal which allows for better cable anchoring and current switching capability. The starter switch hot wire attaches to the spade terminal on the solenoid. These are the only two connections necessary.
 - I. Your starter switch should be capable of switching 30A of 12VDC power and should be at least 14AWG.
 - II. The battery cable must be the proper size for the length of the cable.
 - III. All connections should be clean and tight, and terminals should be soldered.
 - IV. The ground cable is important, and the best ground path is direct to the engine block. With steel frame vehicles the ground path can be to the frame.
 - V. This ground cable should be the same size as the starter positive cable.
 - VI. Using the proper gauge wire is important to the operation of the starter.

CAUTION!

Over tightening of the battery terminal could result in misalignment of the solenoid contact points causing intermittent starter failure. If this occurs by over tightening, remove black steel cover held in place by 3 x hex headed bolts and realign the copper contact so the plunger assembly makes full contact across both contact points.

9. Connect the battery terminals and start the engine.
 - I. Never operate a starter for more than 30 seconds at a time without letting it cool for at least two minutes.
10. Operate the new starter motor - It should operate quietly. Any loud grinding noises must be corrected. If the starter makes a high-pitched whine during cranking the pinion to ring gear engagement is too great. If the starter makes a high-pitched whine after cranking as the button or key is released, the clearance is too small.
11. The cables and connectors themselves should be checked for voltage drop with a voltmeter. To check any wire or cable for voltage drop, connect one side of the voltmeter to one end of the cable and the other side of the voltmeter to the other end.
12. Operate the starter motor circuit and simultaneously measure the volt drop - It should be 0.5VDC or less. High voltage drops indicate a bad connector or undersized cable. The ground circuit can be checked in the same manner. Measure input voltage by connecting the positive probe of a voltmeter to the terminal of the solenoid and connecting the negative to the starter housing [should be 9.0V minimum while cranking].
13. At any time, the voltage at the starter should not be less than 10.0VDC. If an excessive voltage drop exists, measure voltages at each connection in the system and repair the system as necessary. An under-voltage starter can cause excessive load on the starter as well as overload to the starter gear and ring gear.
14. Slow Cranking is due to low input voltage. The battery should be checked, but also inspect the battery wires, terminals, connections or switches.

For more information or technical enquires

Contact: Aeroflow Performance on

Phone: (02) 8825 1979 Website: www.aeroflowperformance.com

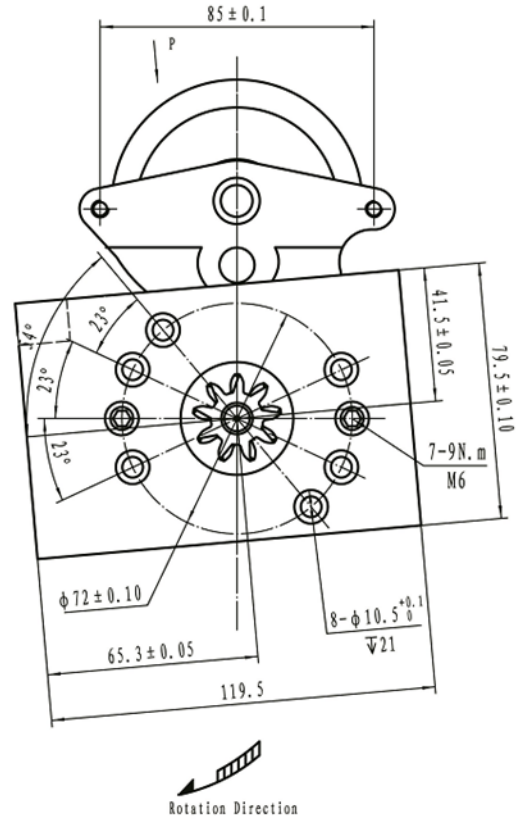
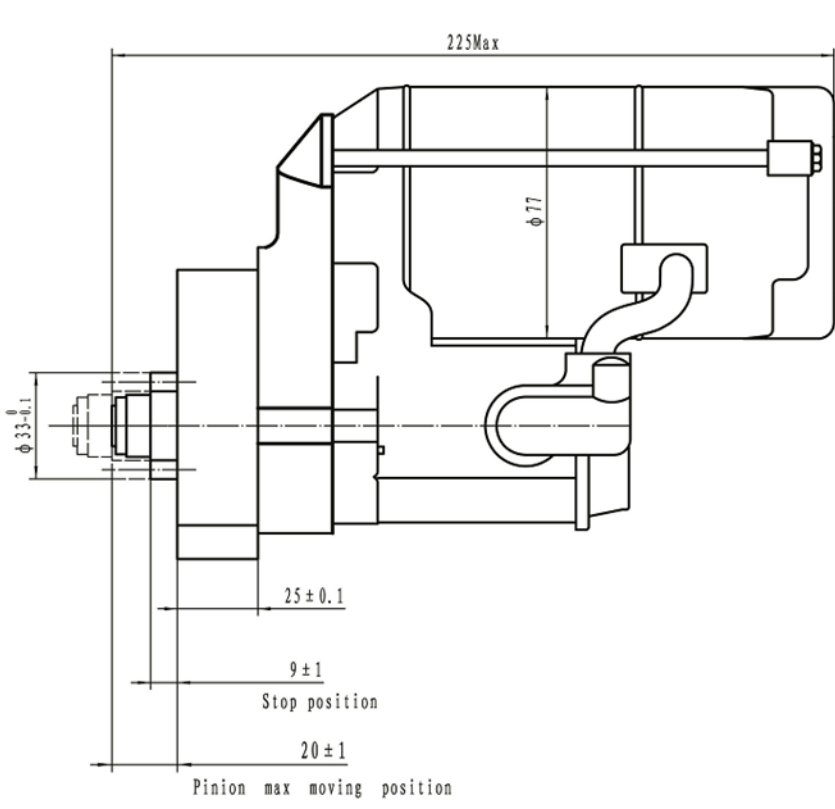
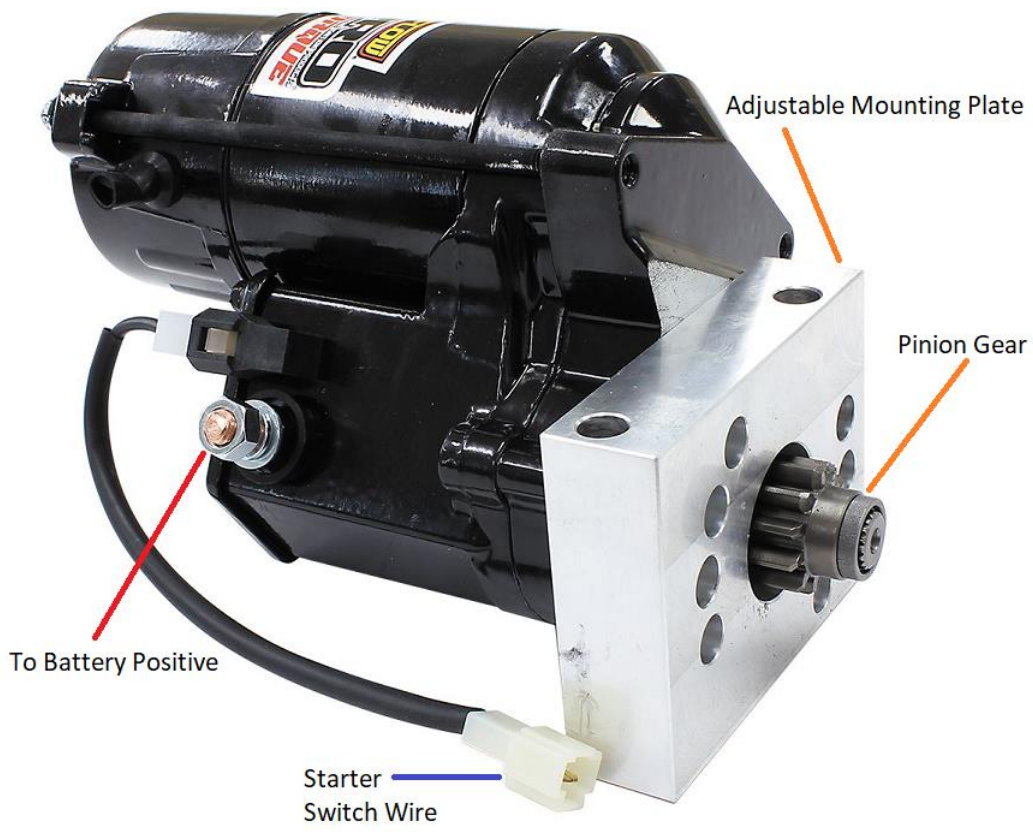

For more information or technical enquires

Contact: Aeroflow Performance on

Phone: (02) 8825 1979 Website: www.aeroflowperformance.com